

# **U**SER MANUAL

---

# *F-Series*

## *Sideshifter*

Manual Number 219941 R-2

**cascade**<sup>®</sup>

Cascade is a Registered Trademark of Cascade Corporation

# **C**ONTENTS

---

	Page
<b>INTRODUCTION</b>	
Special Definitions	2
<b>OPERATION</b>	
Safety Rules	3
Industrial Lift Trucks	3
Handling Loads	4
Sideshifter Operation	4
Safe Operation and Maintenance	5
OSHA Regulations	5
<b>INSTALLATION</b>	
Truck Requirements	6
Recommended Hydraulic Supply	6
Installation Procedure	7
<b>INSPECTION &amp; MAINTENANCE</b>	
Daily	9
100-Hour Maintenance	9
300-Hour Maintenance	9
1000-Hour Maintenance	9
<b>PARTS</b>	
Product Identification	9
Base Unit	10
Cylinder Assembly	11
Recommended Spare Parts	back cover
Publications	back cover
Contacting Cascade	back cover

# INTRODUCTION

This User Manual is for Cascade F-Series Sideshifters. It contains an Operation Guide, Installation Instructions, and Parts Manual. All specifications are shown in U.S. and (Metric) units where applicable.

**IMPORTANT:** All hosing and flared fittings on F-Series Sideshifters are JIC as standard, with face seal as an option.

## Special Definitions

The statements shown appear throughout this Manual where special emphasis is required. Read all **WARNINGS** and **CAUTIONS** before proceeding with any work. Statements labeled **IMPORTANT** and **NOTE** are provided as additional information of special significance or to make the job easier.



**WARNING** – A statement preceded by **WARNING** is information that should be acted upon to prevent **bodily injury**. A **WARNING** is always inside a ruled box.



**WARNING:** Rated capacity of the truck/attachment combination is a responsibility of the original truck manufacturer and may be less than shown on the attachment nameplate. Consult the truck nameplate.

**WARNING:** Do not operate this attachment unless you are a trained and authorized lift truck driver.

**CAUTION** – A statement preceded by **CAUTION** is information that should be acted upon to prevent machine damage.

**IMPORTANT** – A statement preceded by **IMPORTANT** is information that possesses special significance.

**NOTE** – A statement preceded by **NOTE** is information that is handy to know and may make the job easier.

# OPERATION

This Section contains operating instructions for Cascade F-Series Sideshifters. It will help you avoid common errors which often cause damage to the equipment or product being handled.

This information is intended to simplify operator understanding about effective and safe Sideshifter use and operation. Read this information thoroughly before operating the Attachment. Be sure you know and understand all operating procedures and safety precautions. If you have any questions, or don't understand a procedure, ask your supervisor.

**Emphasize Safety!** Most accidents are caused by operator carelessness or misjudgement. You must watch for poorly maintained equipment and hazardous situations and correct them.

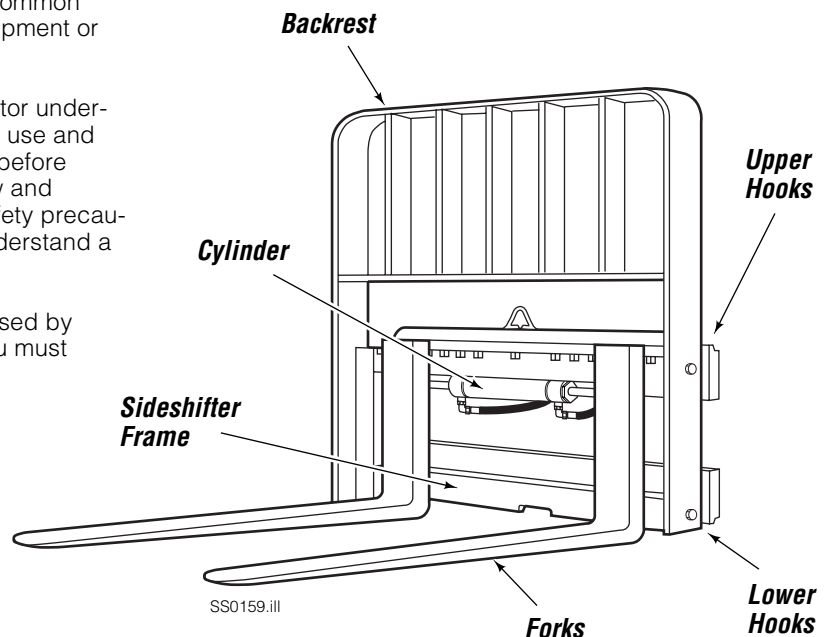

# OPERATION

## Safety Rules – Industrial Lift Trucks

No riders



No reaching through mast



No standing under load



GA0047.iii

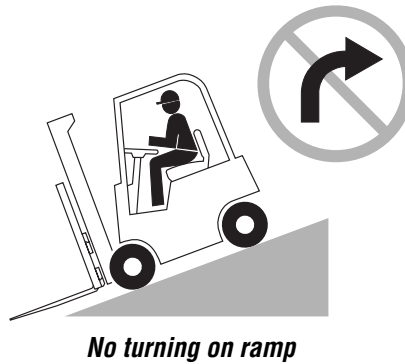
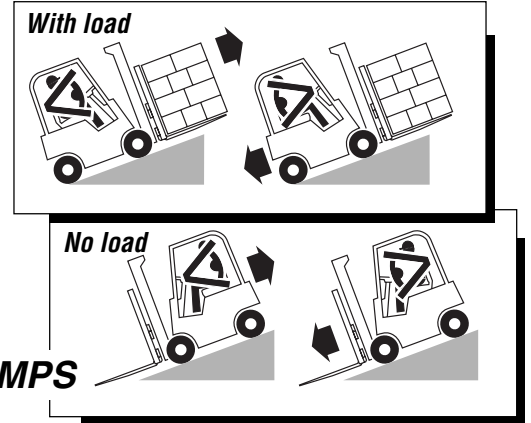
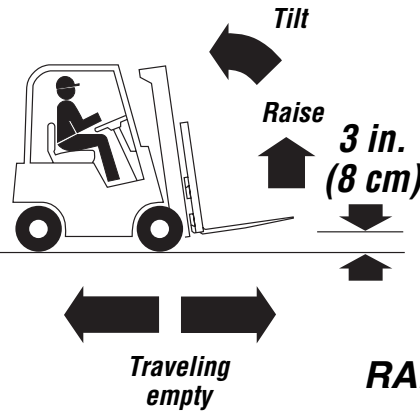
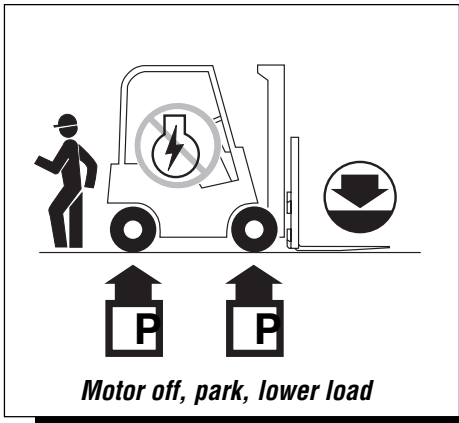

GA0048.iii

<p><b>TRAFFIC</b></p> <p><b>Observe</b></p> <p><b>Wet floors</b></p>			<p><b>Workers</b></p> <p><b>Bumps</b></p>	<p><b>Stops</b></p> <p><b>Dips</b></p>	<p><b>Slow for two-way traffic</b></p>	<p><b>Sound horn, slow at intersection</b></p>	<p><b>Sound horn, slow at corner</b></p>
--	--	--	---	--	--	--	--

# OPERATION

## Safety Rules – Handling Loads

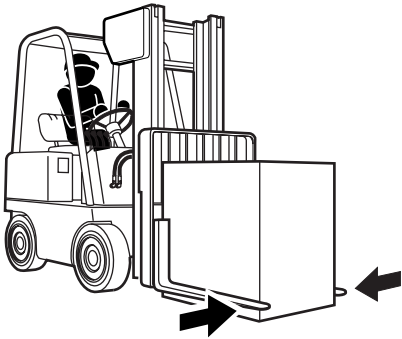

**CAUTION:** Do not put side loads on forks.

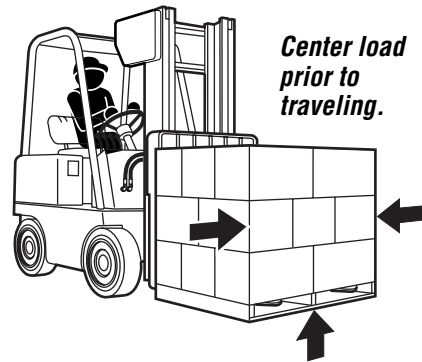

Center load prior to traveling.

Raise load prior to sideshifting.

Limit sideshifting with raised load.

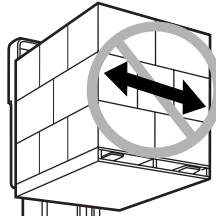

Limit truck movement with raised load.

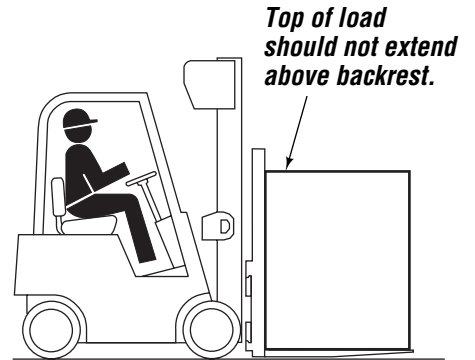

Top of load should not extend above backrest.

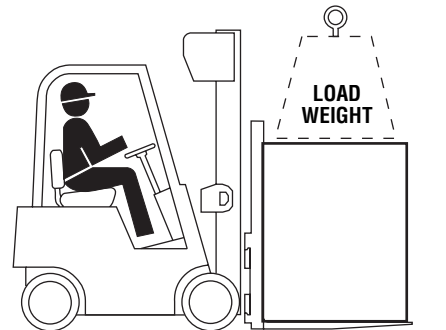

FPO017.iii

Load weight must not exceed combined truck/attachment capacity (see truck nameplate).

Total fork capacity (LH + RH fork) must be greater than load weight. Check capacity stamp on forks.

## Sideshifter Operation

### AUXILIARY VALVE FUNCTIONS

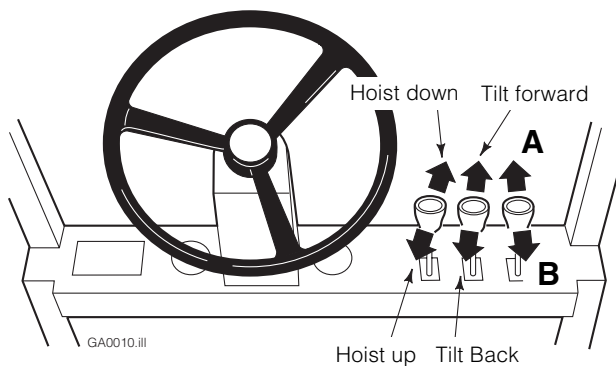

### SIDESHIFTING

- A Sideshift Left
- B Sideshift Right

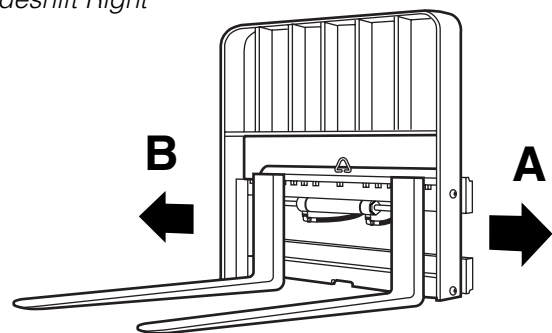

SS0160.iii



# SAFE OPERATION AND MAINTENANCE

## OSHA Regulations – Industrial Trucks and Attachments (Specific Regulations from OSHA 1910.178)



**WARNING:** The safe operation and maintenance of industrial trucks is regulated by Occupational Safety and Health (OSHA) regulations 1910.178 and American National Standards Institute (ANSI) Safety Standard for Powered Industrial Trucks, ANSI B56.1. When operating and maintaining industrial trucks equipped with attachments you should pay particular attention to the following sections of these regulations. You should be familiar with **all** sections of these regulations. **Ask your employer for the complete regulations.**

### (a) General Requirement

- (4) Modifications and additions which affect capacity and safe operation shall not be performed by the customer or user without manufacturers prior written approval. Capacity, operation and maintenance instruction plates, tags or decals shall be changed accordingly.
- (5) If the truck is equipped with front-end attachments other than factory installed attachments, the user shall request that the truck be marked to identify the attachments and show the appropriate weight of the truck and attachment combination at maximum elevation with load laterally centered.
- (6) The user shall see that all nameplates and markings are in place and maintained in a legible condition.

### (e) Safety Guards

- (2) If the type of load presents a hazard, the user shall equip fork trucks with a vertical load backrest extension in accordance with (a)(2) following.
  - (a)(2) All new powered industrial trucks acquired and used by an employer after February 15, 1972 shall meet the design and construction requirements for powered industrial trucks established in the "American National Standard for Powered Industrial Trucks, Part II, ANSI B56.1", except for vehicles intended primarily for earth moving or over-the-road hauling.

### (l) Operator Training

Only trained and authorized operators shall be permitted to operate a powered industrial truck. Methods shall be devised to train operators in the safe operation of powered industrial trucks.

### (m) Truck Operations

- (1) Trucks shall not be driven up to anyone standing in front of a bench or other fixed object.
- (2) No person shall be allowed to stand or pass under the elevated portion of any truck, whether loaded or empty.
- (3) Unauthorized personnel shall not be permitted to ride on powered industrial trucks. A safe place to ride shall be provided where riding of trucks is authorized.
- (4) The employer shall prohibit arms or legs from being placed between the uprights of the mast or outside the running lines of the truck.
- (5i) When a powered industrial truck is left unattended, load engaging means shall be fully lowered, controls shall be neutralized, power shall be shut off and brakes set. Wheels shall be blocked if the truck is parked on an incline.
- (5ii) A powered industrial truck is unattended when the operator is 25 feet or more away from the vehicle which remains in his view, or whenever the operator leaves the vehicle and it is not in his view.
- (5iii) When the operator of an industrial truck is dismounted and within 25 feet of the truck still in his view, the load engaging means shall be fully lowered, controls neutralized and the brakes set to prevent movement.

- (6) A safe distance shall be maintained from the edge of ramps or platforms while on any elevated dock or platform or freight car. Trucks shall not be used for opening or closing freight doors.
- (10) A load backrest extension shall be used whenever necessary to minimize the possibility of the load or part of it from falling rearward.

### (n) Traveling

- (4) The driver shall be required to slow down and sound the horn at cross isles and other locations where vision is obstructed. If the load being carried obstructs forward view, the driver shall be required to travel with the load trailing.
- (7i) When ascending or descending grades in excess of 10 percent, loaded trucks shall be driven with the load upgrade.
- (7iii) On all grades the load and load engaging means shall be tilted back if applicable, and raised only as far as necessary to clear the road surface.

### (o) Loading

- (1) Only stable or safely arranged loads shall be handled. Caution shall be exercised when handling off-center loads which cannot be centered.
- (2) Only loads within the rated capacity of the truck shall be handled.
- (3) The long or high (including multiple-tiered) loads which may affect capacity shall be adjusted.
- (4) Trucks equipped with attachments shall be operated as partially loaded trucks when not handling a load.
- (5) A load engaging means shall be placed under the load as far as possible; the mast shall be carefully tilted backward to stabilize the load.
- (6) Extreme care shall be used when tilting the load forward or backward, particularly when high tiering. Tilting forward with load engaging means elevated shall be prohibited except to pick up a load. An elevated load shall not be tilted forward except when the load is in a deposit position over a rack or stack. When stacking or tiering, only enough backward tilt to stabilize the load shall be used.

### (p) Operation of the Truck

- (1) If at any time a powered industrial truck is found to be in need of repair, defective, or in any way unsafe, the truck shall be taken out of service until it has been restored to safe operating condition.

### (q) Maintenance of Industrial Trucks

- (1) Any power-operated industrial truck not in safe operating condition shall be removed from service. All repairs shall be made by authorized personnel.
- (5) All parts of any such industrial truck requiring replacement shall be replaced only by parts equivalent as to safety with those used in the original design.
- (6) Industrial trucks shall not be altered so that the relative positions of the various parts are different from what they were when originally received from the manufacturer, nor shall they be altered either by the addition of extra parts not provided by the manufacturer or by the elimination of any parts. Additional counter-weighting of fork trucks shall not be done unless approved by the truck manufacturer.
- (7) Industrial trucks shall be examined before being placed in service and shall not be placed in service if the examination shows any condition adversely affecting the safety of the vehicle. Such examinations shall be made at least daily. When industrial trucks are used on a round-the-clock basis, they shall be examined after each shift. Defects when found shall be immediately reported and corrected.

## Truck Requirements

### Truck Relief Setting

2000 psi (140 bar) Recommended  
3500 psi (240 bar) Maximum

### Truck Flow Volume <sup>①</sup>

	Min. <sup>②</sup>	Recommended	Max. <sup>③</sup>
<b>55F</b>	1 GPM (4 L/min.)	2 GPM (7.5 L/min.)	3 GPM (12 L/min.)

- ① Cascade F-Series Sideshifters are compatible with SAE 10W petroleum base hydraulic fluid meeting Mil. Spec. MIL-0-5606 or MIL-0-2104B. Use of synthetic or aqueous base hydraulic fluid is not recommended. If fire resistant hydraulic fluid is required, special seals may be required. Contact Cascade.
- ② Flow less than recommended will result in slow sideshift speed.
- ③ Flow greater than maximum can result in excessive heating, reduced system performance and reduced hydraulic system life.

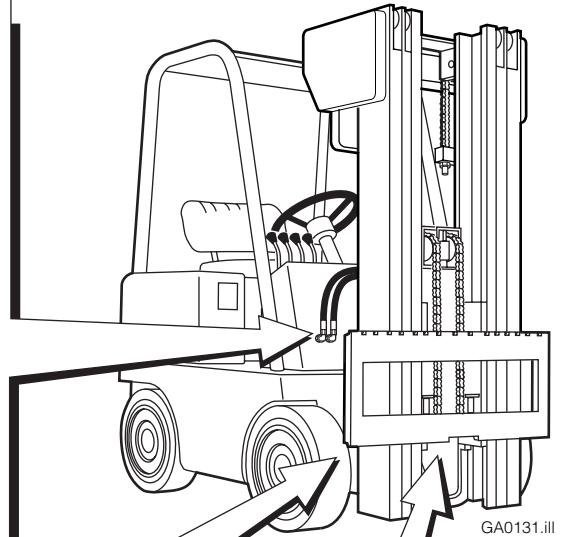

GA0131.iii

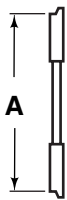

GA0028.iii

### Carriage Mount Dimension (A) ITA (ISO)

	Minimum	Maximum
<b>Class II</b>	14.94 in. (380.0 mm)	15.00 in. (381.0 mm)

**Carriage** – Clean and inspect carriage bars. Assure that bars are parallel and that ends are flush. Grind smooth any protruding welds that may affect Sideshifter lower bearings. Repair any damaged notches.

## Recommended Hydraulic Supply

The Sideshifter will require one of the hydraulic supply arrangements shown below. All hoses and fittings should be at least No. 4 with 3/16 in. (5 mm) minimum I.D. Refer to *Cascade Hose & Cable Reel Selection Guide*, Part No. 212199 to select the correct hose reel for the mast and truck.

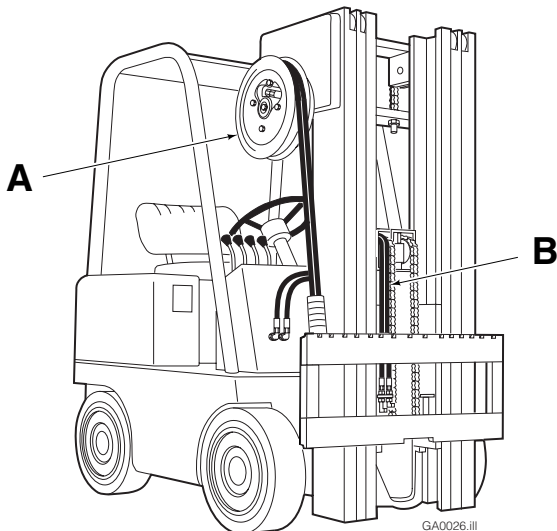

GA0026.iii

### Auxiliary Valve Functions

Check for compliance with ITA (ISO) standards:

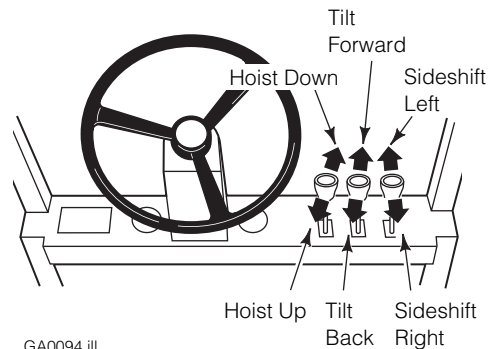

GA0094.iii

- A** RH THINLINE™ 2-Port Hose Reel Supply Group
- OR**
- B** Mast Single Internal Hose Reaving

## Installation Procedure

**WARNING:** Make sure overhead hoist has a rated capacity of at least 1000 lbs. (450 kg).

### 1 Attach overhead hoist

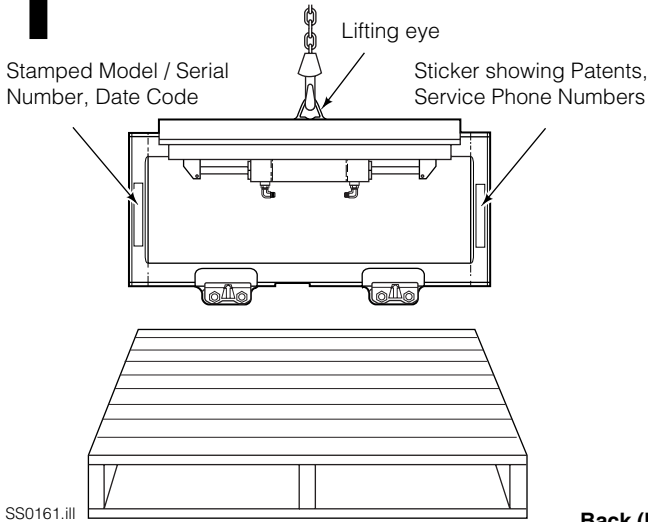

### 2 Remove bolt-on lower hooks

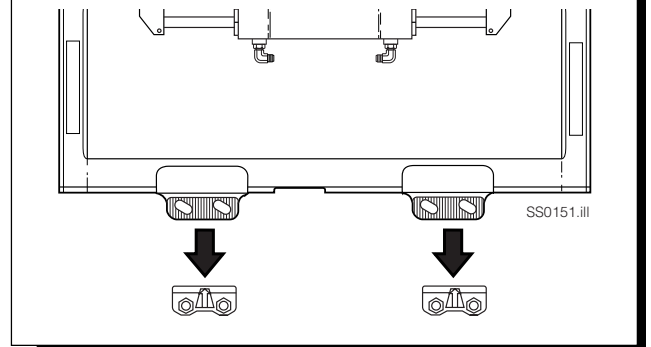

Back (Driver's) Views

### 3 Mount Sideshifter on truck carriage

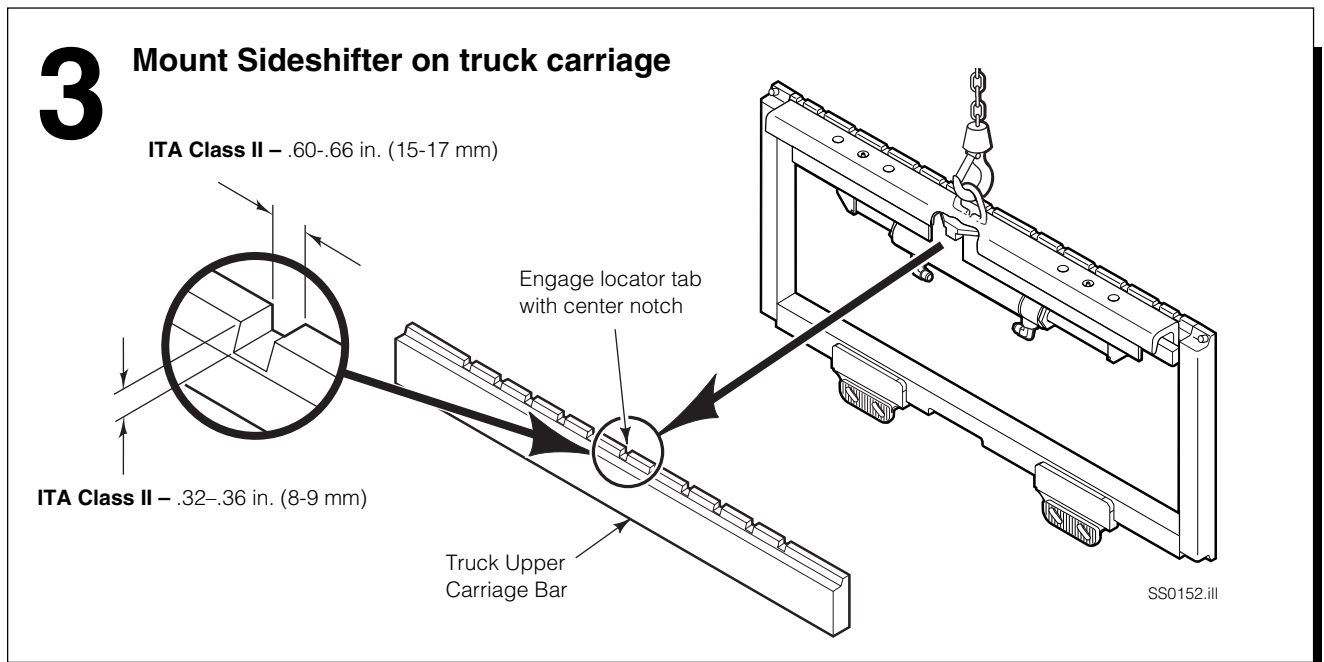

### 4 Install lower hooks

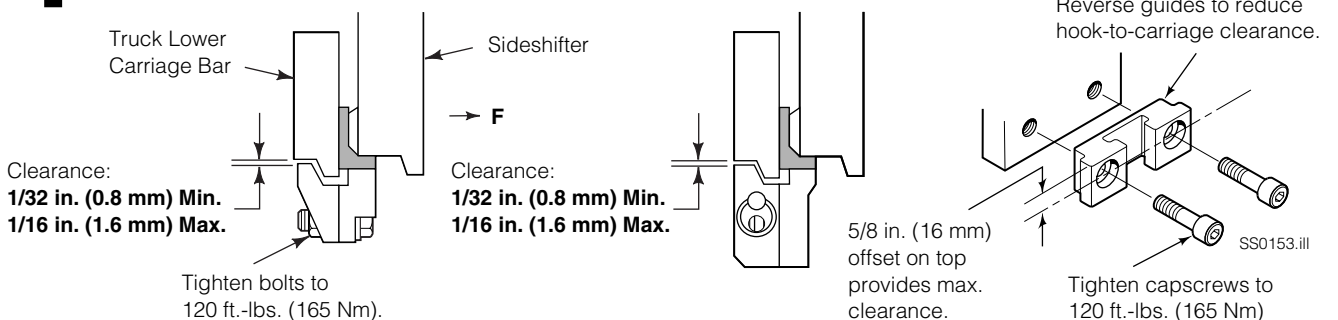

## 5 Flush supply hoses

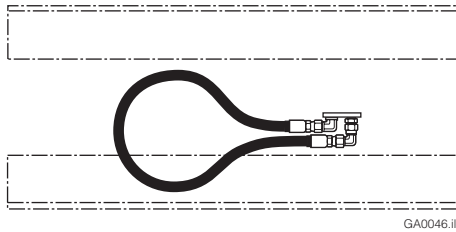

GA0046.ill

## 6 Install hoses

Optional Installation Kit 205826 shown for internal reeving.

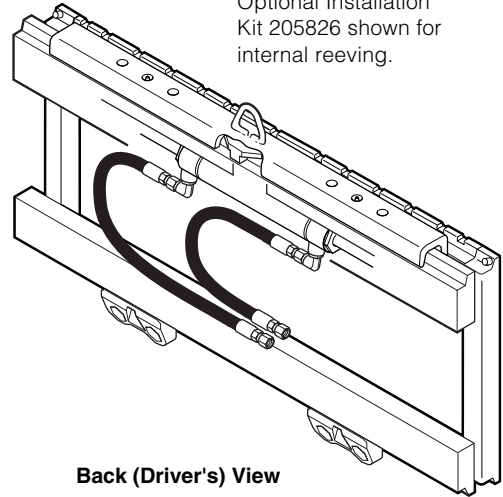

Back (Driver's) View

SS0154.ill

## 7 Install forks

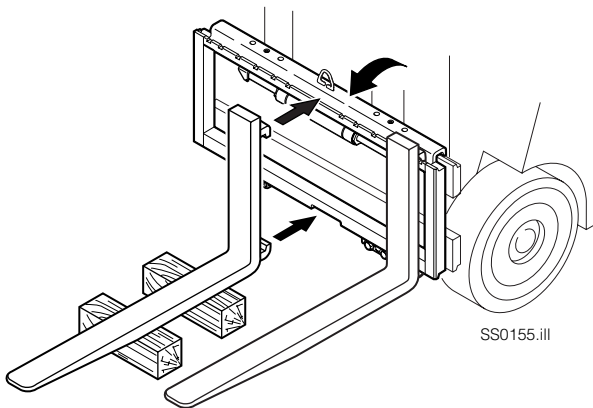

SS0155.ill

## 8 Install backrest

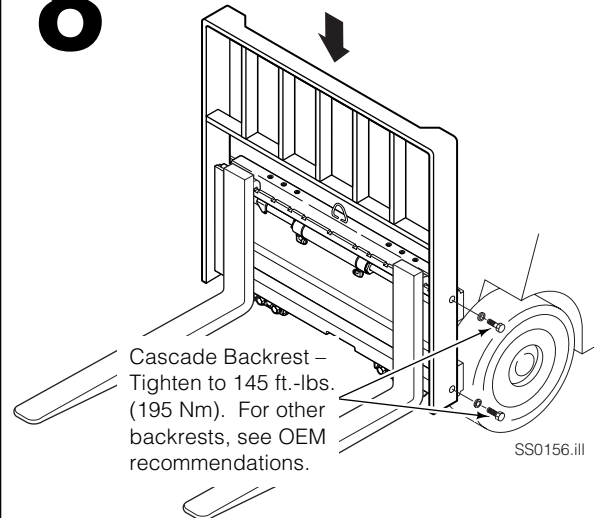

Cascade Backrest – Tighten to 145 ft.-lbs. (195 Nm). For other backrests, see OEM recommendations.

SS0156.ill

## 9 Lubricate lower bearings

Lubricate lower bearings with general-purpose lithium-based chassis grease.

**NOTE:** Upper bearings are prelubed at the Factory with break-in grease. No lubrication is required during installation.

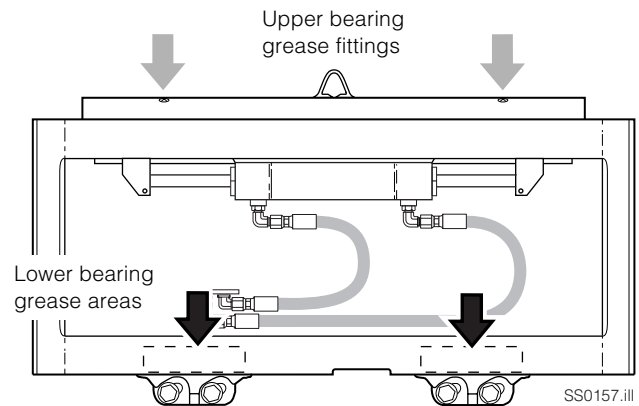

Upper bearing grease fittings

Lower bearing grease areas

SS0157.ill

Front View

# INSPECTION & MAINTENANCE



**WARNING:** After completing any service procedure, always test the sideshifter through five complete cycles. First test with no load, then test with a load to make sure the attachment operates correctly before returning it to the job.

## Daily

Check items shown each day. Report problems to your supervisor. See Service Manual for troubleshooting, maintenance and repair procedures.

## 100-Hour

Every time the lift truck is serviced or every 100 hours of truck operation, whichever comes first, complete the following maintenance procedures:

- Check for loose or missing bolts, worn or damaged hoses, hydraulic leaks, and damaged or missing fork stops.
- Inspect lower hooks for wear and proper clearance. Adjust if necessary (see Step 4, Installation). Tighten lower hook capscrews to 120 ft.-lbs (165 Nm).

## 300-Hour

After each 300 hours of truck operation, in addition to the 100-hour maintenance, perform the following procedures:

- Tighten backrest capscrews (Cascade) to 145 ft.-lbs. (195 Nm).
- Apply general-purpose lithium-based chassis grease to Sideshifter upper and lower bearings.

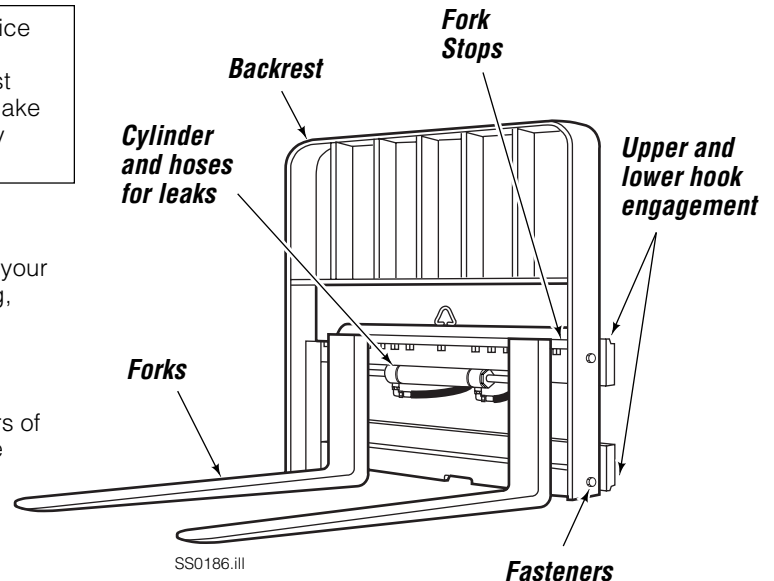

## 1000-Hour

After each 1000 hours of truck operation, in addition to the 100 and 300-hour maintenance, perform the following procedures:

- Inspect upper and lower bearings for wear. If any bearing is worn to less than 3/32 in. (2.5 mm) thickness, replace the entire bearing set. See Service Manual for replacement procedure.
- Inspect forks for wear. **NOTE:** Fork Safety Kit 3014162 is available containing wear calipers, inspection sheets and safety poster. Also available is fork hook & carriage wear gauge 209560 (CL II), and 209561 (CL III).

# PARTS

**Product Identification** – This Section shows replacement parts for F-Series Sideshifters. The product model number and serial number are stamped on the back surface of the LH vertical bar (driver's view), and must be provided when ordering replacement parts. The cylinder/anchor bracket assembly part number is stamped on the front surface RH end of the anchor bracket (driver's view).



**WARNING:** For the safety of yourself and others, DO NOT install the parts shown in this Manual unless you have thoroughly reviewed the appropriate Service Manual.

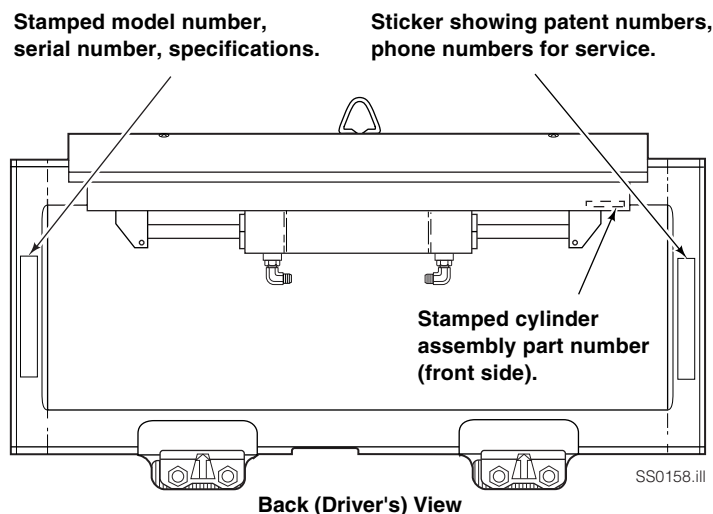

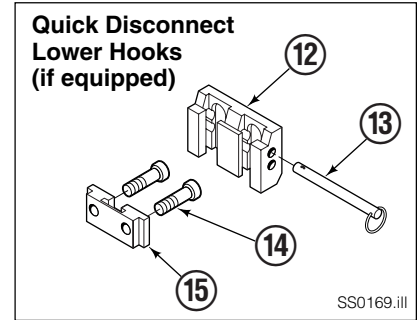
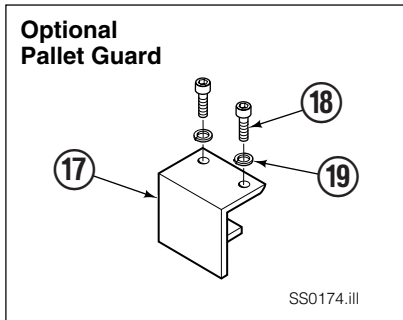
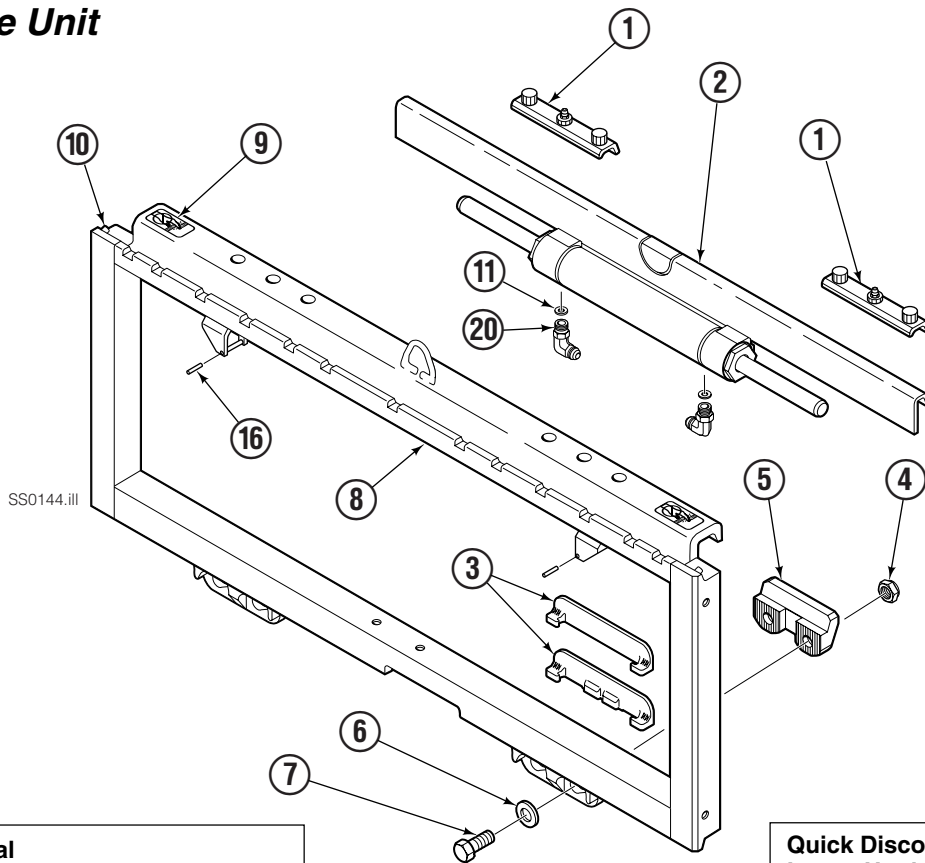

55F							
REF	QTY	PART NO.	DESCRIPTION	REF	QTY	PART NO.	DESCRIPTION
1	▼	6020486	Upper Bearing Kit, Composite	11	2	221733	Flow Restrictor, 1.5 mm ID
1	▼	6033485	Upper Bearing Kit, Bronze (option) ✱	12	2	675514	Q.D. Lower Hook
1	▼	6033486	Upper Bearing Kit, Bronze (option) ✚	13	2	678832	Pin
2	1	■	Cylinder Assembly	14	4	683182	Capscrow, M16 x 35
3	▼	6033487	Lower Bearing Kit, Composite	15	2	675515	Guide
3	▼	226842	Lower Bearing Kit, Bronze (optional)	16	2	7891	Roll Pin, .188 dia. x 1.625
★ 4	4	553857	Nut, 5/8 NC, GR5	◆17	1	220689	Pallet Guard
★ 4	4	781534	Nut, M16	◆18	2	769573	Capscrow, M16
★ 5	2	204186	Lower Hook	◆19	2	684586	Lockwasher
5	2	228166	Lower Hook, Bronze (optional)		2	601676	Fitting-90, JIC 6-6
★ 6	4	667225	Washer, 5/8		2	207304	Fitting- Long 90, JIC 6-6
★ 7	4	639121	Capscrow, 5/8 NC x 1.5, GR5		2	667222	Fitting-90, JIC 5-6
★ 7	4	766154	Capscrow, M16 x 45, GR8.8	20	2	666984	Fitting-90, JIC 4-6
8	1	●	Frame		2	604511	Fitting-Straight, JIC 6-6
9	2	221906	Safety Decal		2	211807	Fitting-90, Face Seal 4-6
10	1	219400	Fork Stop Kit (Includes 2 stops)		2	220832	Fitting-Straight, Face Seal 4-6

- ▼ Kits contain 2 bearings.
- ✱ Order Kit 6033485 for cylinder stamped 10039-XX.
- ✚ Order Kit 6033486 for cylinder stamped 21006-XX or 6XXXXXX.
- See Cylinder page for parts breakdown.
- ★ Included in Lower Hook Service Kit 204182
- If Frame needs replacing, order complete Sideshift Assembly
- ◆ Included in Pallet Guard Kit 220688.

Reference: SK-6349

# PARTS

## Cylinder Assembly

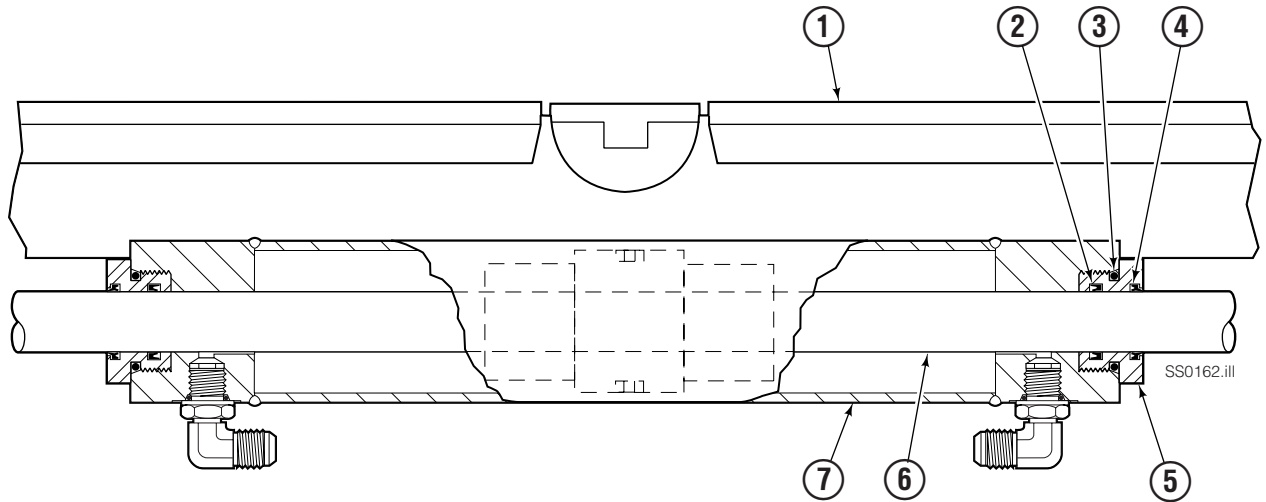

55F			
REF	QTY	PART NO.	DESCRIPTION
★ 1	1	10039-XXX◆	Cylinder Assembly
1	1	21006-XXX◆	Cylinder Assembly
1	1	6XXXXXX◆	Cylinder Assembly
● 2	2	562132	Rod Seal
● 3	2	415866	O-Ring, 70 Duro
● 4	2	562131	Rod Wiper Seal
5	2	218324	Retainer/Seal Carrier
6	—	■	Rod/Piston Assembly
7	—	■	Cylinder Shell
		219868	Rod Seal Service Kit

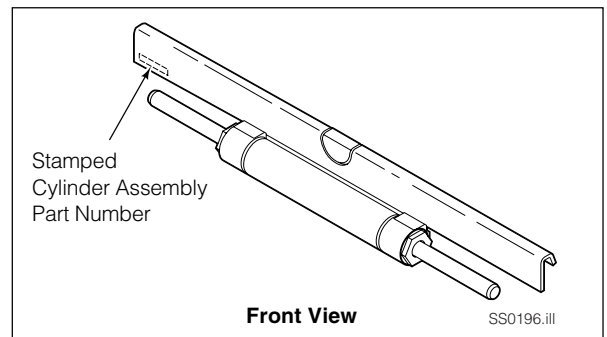

- ★ No longer available. Replaced by current Cylinder Assembly plus Bearing Service Kit 6000617 or 6000618 which includes roll pins and upper bearings.
  - Included in Service Kit 219868.
  - Not serviceable, order new Cylinder Assembly.
  - ◆ Refer to complete part number stamped on cylinder assembly, or serial number stamped on frame.
- Reference: S-10039

### Backrest

55F					
		Backrest Height			DESCRIPTION
		36 in. (91.5 cm)	48 in. (122 cm)	60 in. (152.5 cm)	
REF	QTY	PART NO.	PART NO.	PART NO.	
1	1	684769	684770	684771	Backrest – 31 in. (78.7 cm) Width
1	1	684772	684773	684774	Backrest – 37 in. (94 cm) Width
1	1	684775	684776	684777	Backrest – 41 in. (104 cm) Width
1	1	684778	684779	684780	Backrest – 49 in. (124.5 cm) Width
1	1	684781	684782	684783	Backrest – 61 in. (155 cm) Width
2	4		200173		Capscrew, M16x2 x 35
3	4		684586		Lockwasher, M16

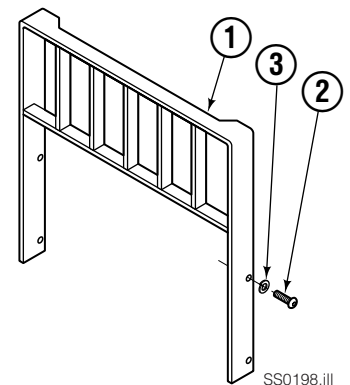

Reference: S-3370

## Recommended Spare Parts

55F		UNITS SERVICED		
PART NUMBER	DESCRIPTION	1-5	6-19	20-50
<b>BASE UNIT AND MOUNTING</b>				
■	Upper Bearing	8	16	32
■	Lower Bearing	6	12	24
204186	Lower Hook	0	2	4
■	Capscrew	0	4	8
■	Nut	0	4	8
667225	Washer	0	4	8
<b>CYLINDER</b>				
21006-XXX■	Cylinder Assembly	0	0	1
6XXXXXX■	Cylinder Assembly	0	0	1
219868	Cylinder Service Kit	1	2	4

■ See specific parts page for part number.

## Publications

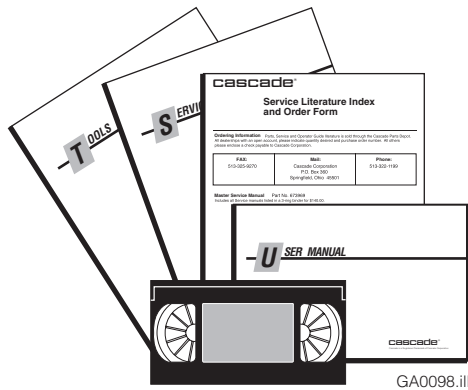

55F	
PART NO.	DESCRIPTION
219941	User Manual (Operation, Installation, Parts)
220526	Service Manual
679929	Tool Catalog
673964	Literature Index Order Form

## Contacting Cascade

**Customers** – Cascade product literature, service literature, parts and videos are available through authorized lift truck dealers. To find the dealer nearest you, contact:

**Cascade Corporation  
U.S. Headquarters**  
2201 NE 201st  
Fairview, OR 97024-9718  
Tel: 800-CASCADE (227-2233)  
503-669-6300  
FAX: 888-329-8207

**Lift Truck Dealers** – To order parts, service literature or videos:

**Cascade Parts Sales**  
2501 Sheridan Ave.  
Springfield, OH 45505  
Tel: 888-CASCADE (227-2233)  
FAX: 888-329-0234

