

## Dual IHR Hose Tracking Improvement Field Kit

### Scope:

Remove and/or replace mounting brackets and shorten hose lengths to improve tracking of the Dual IHR hoses.

### Process:

Kit Part Number: 261625

Item #	Qty	Part Number	Description
1	1	262662	bracket, hose clamp
2	1	291445	clamp, hose, #6
3	1	290464	cover plate, hose clamp
4	1	290465	bolt, hose clamp
5	1	259910	bracket, left hand, carriage
6	1	260597	bracket, right hand, carriage
7	4	215644	fitting, #6 hose, Parker

1. Replace existing bracket, hose clamp, flat washer, and capscrew (see Figure 1) with updated bracket, clamp, cover plate, and bolt (items 1, 2, 3, & 4) shown in Figure 2. Clamp (item 2) should be aligned with pad on bracket (item 1) before tightening cover plate and bolts (items 3 & 4). M6 hardware for mounting bracket is to be reused and should be torqued to 8Nm (71 in-lbs).

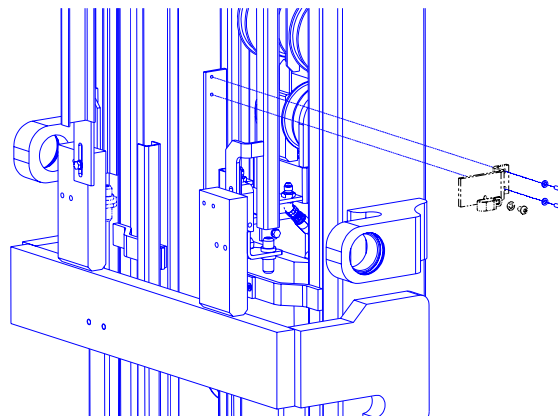
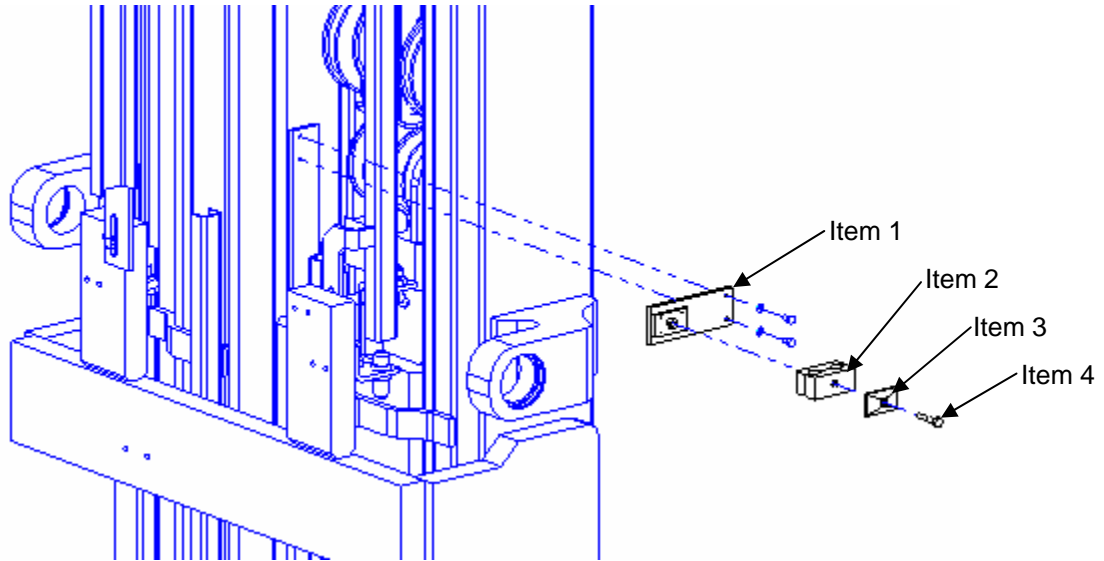

Figure 1

**TECHNICAL BULLETIN 262007**

7040 South Highway 11 • Westminster, SC 29693 • Toll Free (888) 946-3330 • (864) 647-1119 • FAX (864) 647-6195



**Figure 2**

2. Replace existing brackets holding #6 90° hose fittings to carriage assembly with new brackets (items 5 and 6) with longer adjustment slots (see Figure 3). M8 hardware for mounting bracket to be torqued to 20Nm (177 in-lbs).

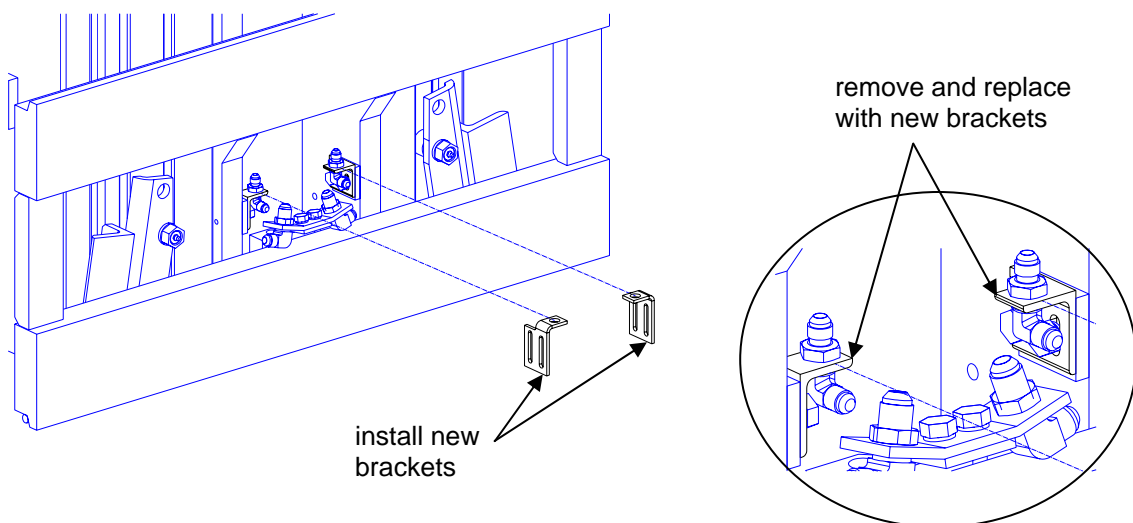

**Figure 3**

## **TECHNICAL BULLETIN 262007**

7040 South Highway 11 • Westminster, SC 29693 • Toll Free (888) 946-3330 • (864) 647-1119 • FAX (864) 647-6195

3. Shorten #6 hose running from the carriage assembly to the inside of the inner weldment by 50 mm (2.0 in). Install new hose fitting (item 7, Parker Hannifin part number 10643-6-6) per the fitting manufacturer's instructions. Typical for two hoses.
  
4. Shorten #6 hose running from the inside of the inner weldment to the upper back of the outer weldment by 190 mm (7.5 in). Install new hose fitting (item 7, Parker Hannifin part number 10643-6-6) per the fitting manufacturer's instructions. Typical for two hoses.