

Installation Instructions

D-Series Mast Cylinder Seal Service Kits

This sheet provides instructions for cylinder seal kit installation and using the loader supplied with each cylinder service kit.

- 1 Use a claw type spanner wrench to remove the cylinder retainer.
- 2 Remove the plunger-piston assembly from the shell.
- 3 Place the retainer in a soft-jawed vise to remove the seals. Never clamp the cylinder plunger sealing surface in a vise. Pry the seal up with a blunt screwdriver and cut the seal to remove it. **CAUTION:** Do not scratch the seal grooves.
- 4 Inspect the plunger, piston, retainer and cylinder bore for nicks and burrs. Minor nicks and burrs can be removed with 400 grit emery cloth. **NOTE:** Minor nicks are those that will not bypass oil under pressure. If nicks can be felt with a fingernail after using emery cloth, replace the part.

NOTE: To disassemble the piston/plunger, see the procedures on the back of this sheet.

- 5 Lubricate the new seals with petroleum jelly prior to installation. Replace the retainer and piston seals, back-up rings, O-rings and bearing. Note the correct seal directions. The cylinder will not operate correctly if the seals are installed backwards.

- 6 **CYLINDERS WITH INTERNAL CHECK VALVE** - When replacing the piston check valve O-ring, make sure the check valve is reinstalled with the arrow pointed in the correct direction.

Claw Type Spanner Wrench

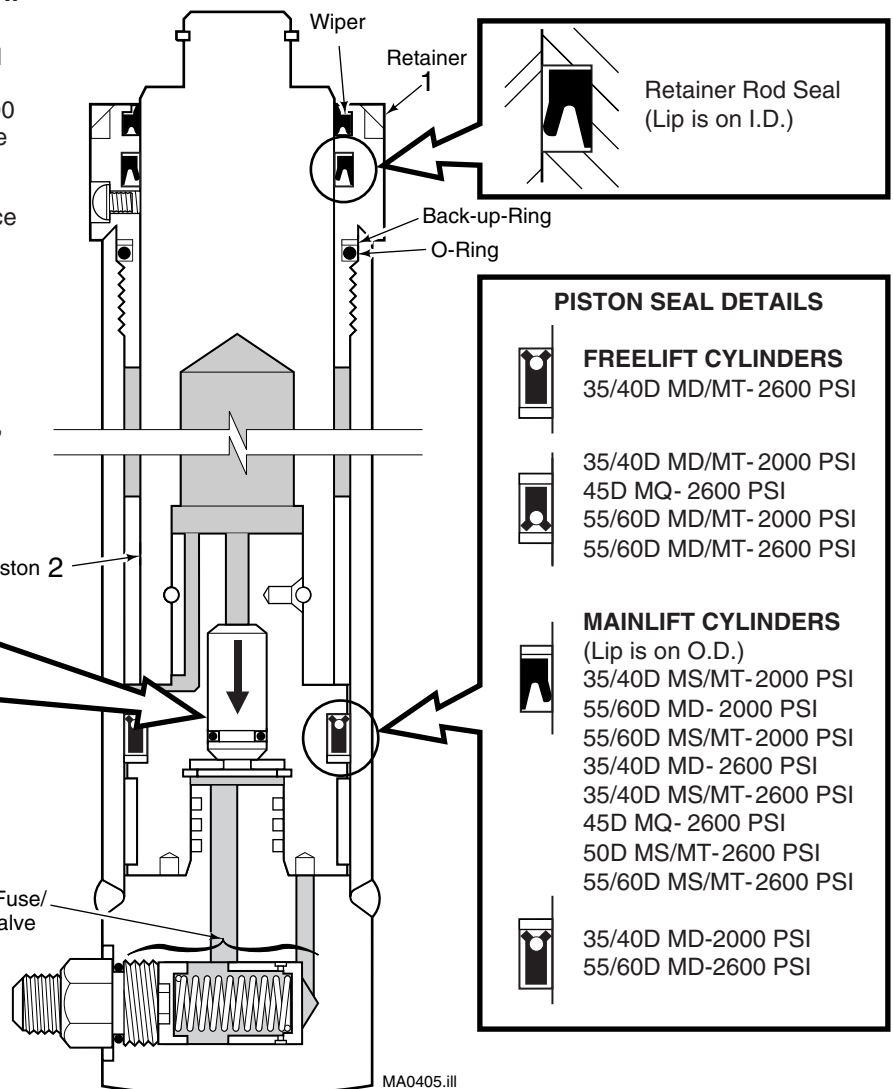
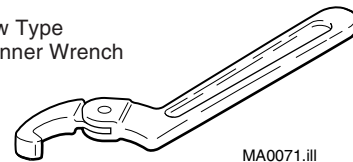

Part No. 688381 R-5

For Technical Assistance and to Order Parts . . .

Call: 1-888-946-3330 or Write: Lift Technologies, 7040 South Highway 11, Westminster, S.C. 29693

- 7 Place the loader in the cylinder shell. The loader must cover all the threads but not contact the thread relief chamfer. The length of the stop fins can be trimmed with a sharp knife if more engagement is needed. The piston will not enter the shell if the loader contacts the thread relief chamfer.
- 8 Apply a thick film of petroleum jelly or hydraulic oil to the inside of the cylinder shell, piston loader and piston seals.
- 9 Insert the plunger/piston assembly through the loader into the cylinder shell. If resistance is encountered, tap the plunger with a rubber mallet. Remove the loader.
- 10 Install the retainer on the plunger assembly.
- 11 Screw in the retainer and tighten to a torque of 225-250 ft.-lbs. (305-340 Nm) using the claw type spanner wrench.

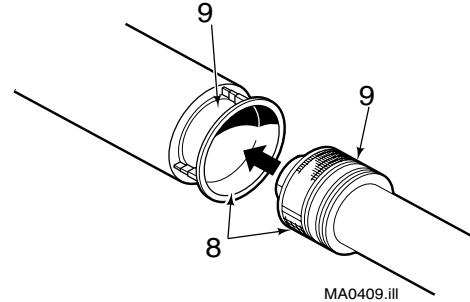
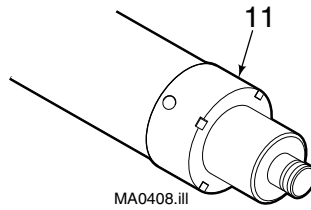
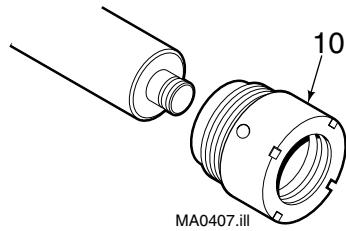
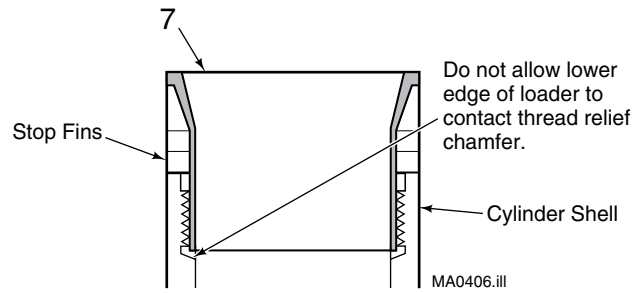

Piston/Plunger Disassembly

- 1 Use a strap wrench and 400 grit emery cloth to secure the plunger while turning the piston with a pin type spanner wrench.
- 2 Turn the piston until the snap wire end is visible through the hole. Use a screwdriver to start the wire end out the hole. Turn the piston to feed the wire out.
- 3 Pull the piston from the plunger.
- 4 For reassembly, reverse the above procedures except as follows:
 - * Install a new snap wire when installing the piston.

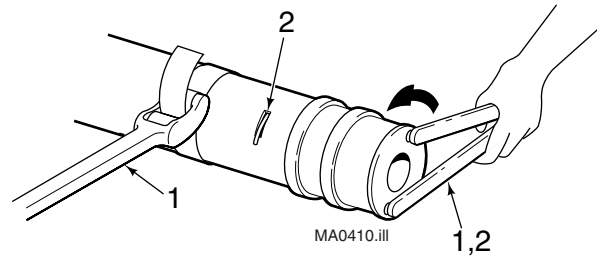

Seal loader kits are available through our Parts Department 1-888-946-3330. Determine the cylinder bore size and order the appropriate loader kit number listed below.

Loader Kit Part No.	Nominal Cylinder Bore Diameter	Loader Kit Part No.	Nominal Cylinder Bore Diameter
561780	1.98 in.	672908	3.25 in.
672904	2.00 in.	584250	3.35 in.
672905	2.25 in.	672909	3.50 in.
561777	2.38 in.	561781	3.56 in.
672906	2.75 in.	672910	4.00 in.
561779	2.96 in.	672911	4.50 in.
561778	2.97 in.	672912	5.00 in.
672907	3.00 in.	672918	5.50 in.
672951 Complete Kit (all loaders listed)		672913	6.00 in.